Hamiltonian Cycle with VQA

김진수, 전유성, 한재훈

Contents

1. Introduction

2. Trials

3. Method

4. Result

1. Introduction

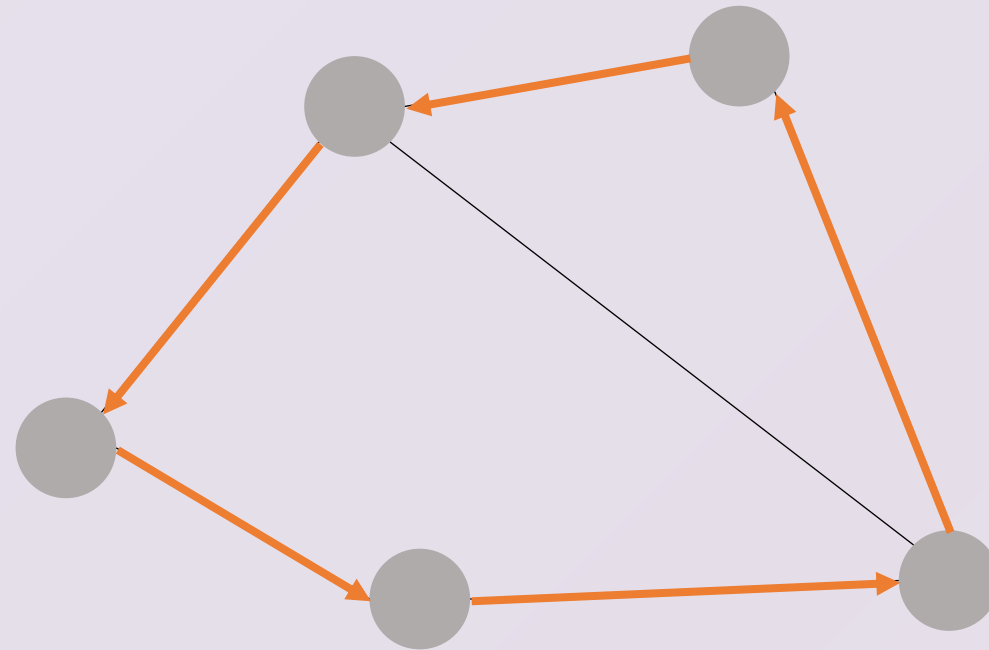

1. Introduction

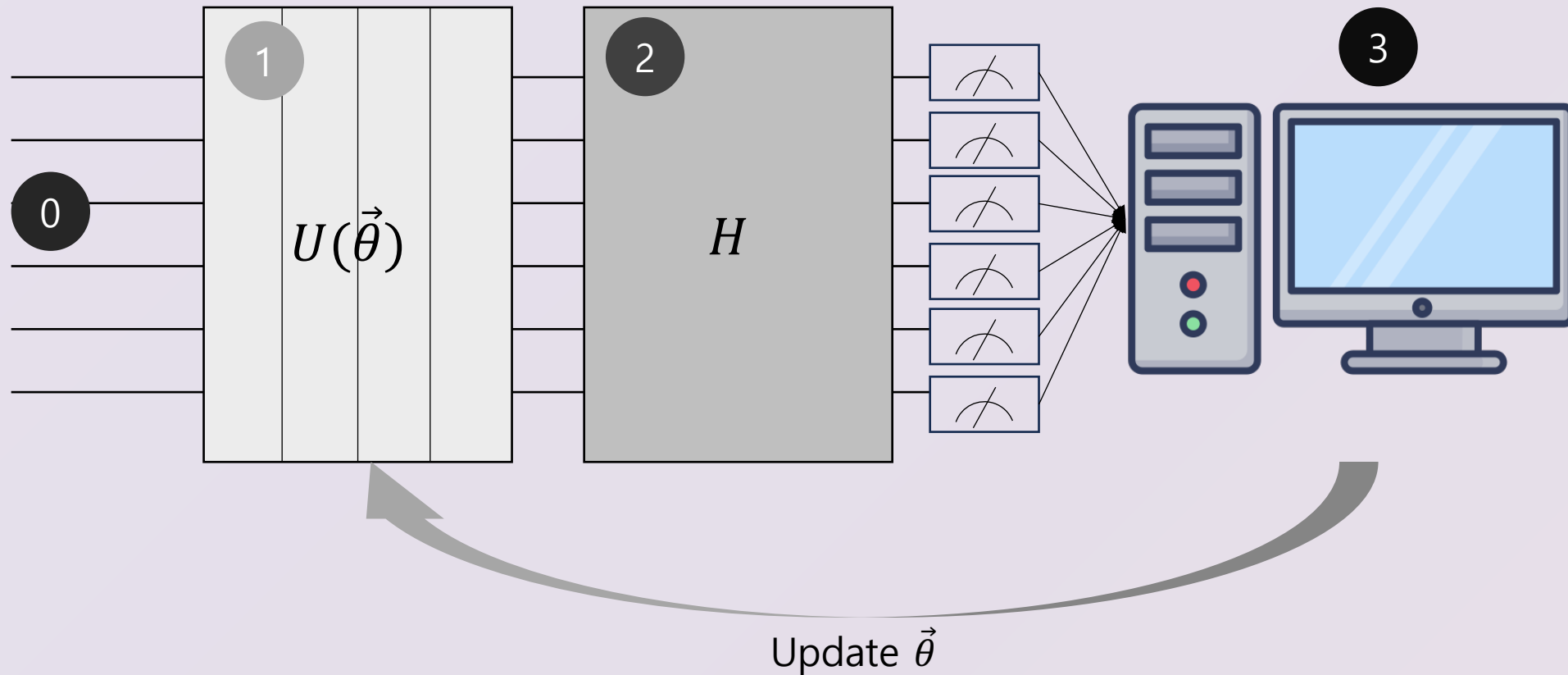

2. Trials

1

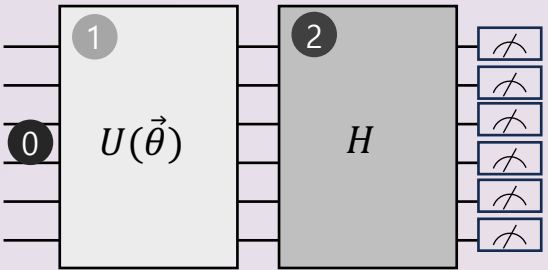
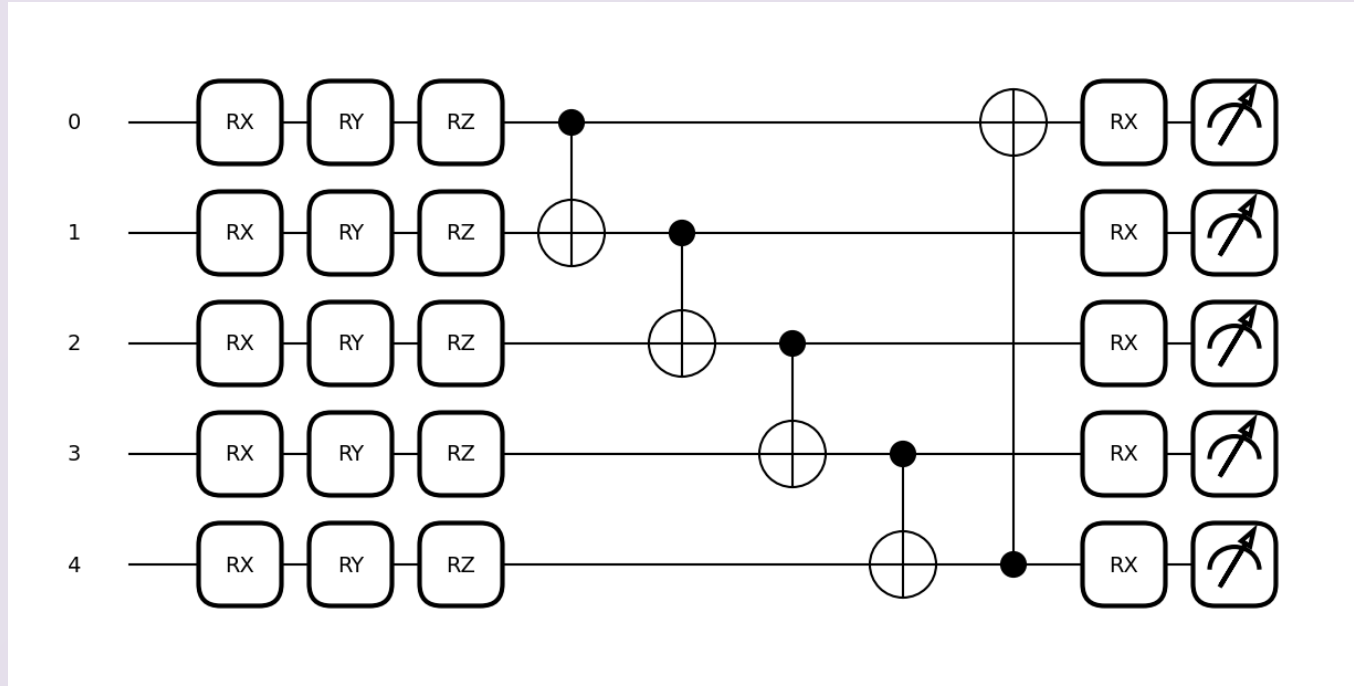

2. Trials

0 2

$|000000\rangle$

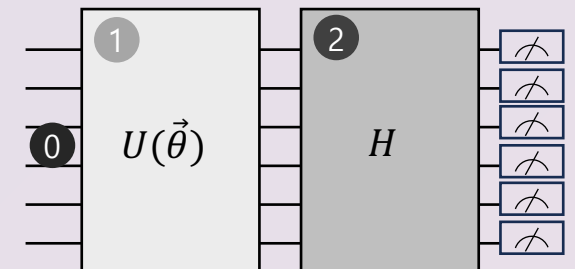
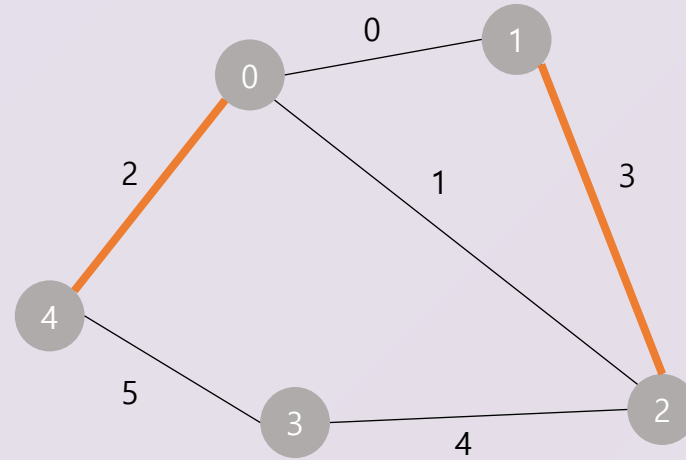

2. Trials

2

**Necessary
Cond.**

of connected edges per node = 2

Want $f : \mathbb{C}^{2^{\otimes |E|}} \rightarrow \{0, \mathbb{R} - \{0\}\}$ $\left\langle \begin{array}{l} \# \text{ of conn. edg.} = 2 \rightarrow f \text{ gives } 0 \\ \# \text{ of conn. edg.} \neq 2 \rightarrow f \text{ gives } \mathbb{R} - \{0\} \end{array} \right.$

$$f_v := \frac{\sigma_{z, e_v} - 1}{2} + 2\mathbb{I}, \quad e_v \in \{\text{Edges connected to vertex } v\}$$

$$C := \sum_{v \in V} \frac{\sigma_{z, e_v} - 1}{2} + 2|V| \cdot \mathbb{I}, \quad V := \{\text{Set of vertices}\}$$

$$H := C^\dagger C$$

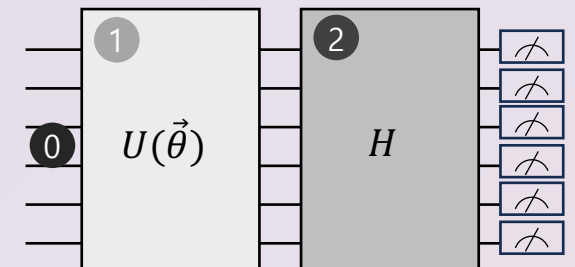
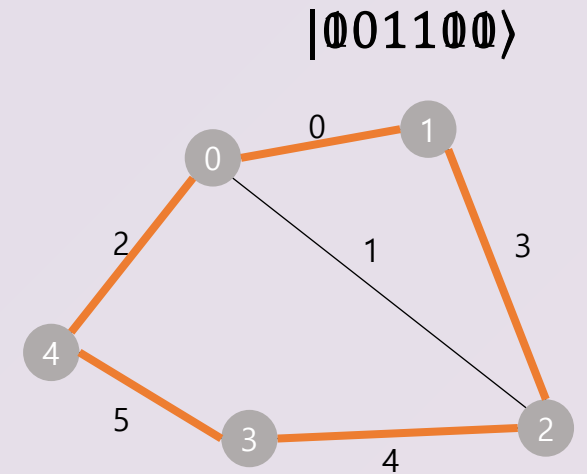

2. Trials

1 2

Necessary Cond.

of connected edges per node = 2 $H := C^\dagger C$

Edges (# of 1s) = # Nodes(Vertices) → **Dimension ↓**

Theoretical Base : Singular Value Decomposition

$|0111111\rangle$
 $|1101111\rangle$
 $|1110111\rangle$
 ...
 $|1111110\rangle$

$\dots E C_V$ (6개) → 1. 큐비트 $|E|$ 개에서 3개로
 2. 남는 2개에는 불필요한 state 부여

$T^\dagger = \begin{bmatrix} 0 & 0 & \dots & 1 \\ \dots & \dots & \dots & \dots \\ 1 & 0 & \dots & 0 \\ \dots & \dots & \dots & \dots \\ 0 & 1 & \dots & 0 \\ \dots & \dots & \dots & \dots \end{bmatrix}$

$\leftarrow 1^{st} \text{ row (redundant state)}$
 $\leftarrow 31^{th} \text{ row } (011111_2 = 31)$
 $\leftarrow 47^{th} \text{ row } (101111_2 = 47)$

$H_r := THT^\dagger$

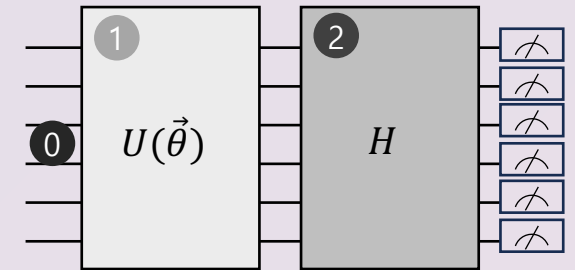
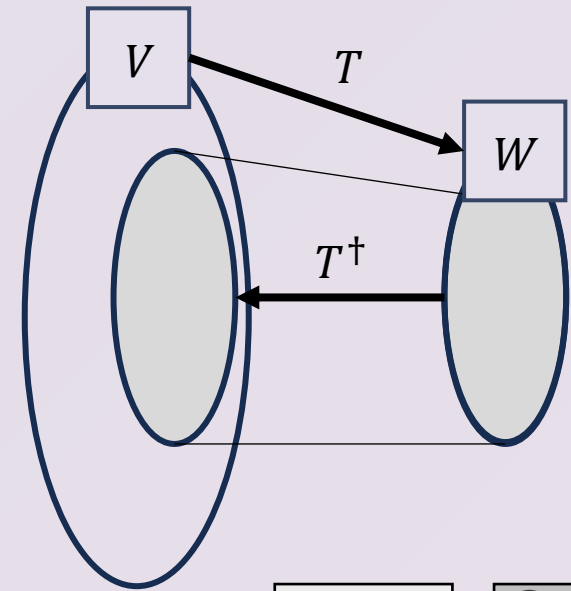

2. Trials

1 2

**Necessary
Cond.**

of connected edges per node = 2 $H := C^\dagger C$

Edges (# of 1s) = # Nodes(Vertices) → **Dimension** ↓ $H_r := THT^\dagger$

Problems of $H_r := THT^\dagger$

$$T^\dagger = \begin{bmatrix} 0 & 0 & \dots & 1 \\ \dots & \dots & \dots & \dots \\ 1 & 0 & \dots & 0 \\ \dots & \dots & \dots & \dots \\ 0 & 1 & \dots & 0 \\ \dots & \dots & \dots & \dots \end{bmatrix}$$

$\leftarrow 1^{st} \text{ row (redundant state)}$
 $\leftarrow 31^{th} \text{ row } (011111_{(2)} = 31)$
 $\leftarrow 47^{th} \text{ row } (101111_{(2)} = 47)$

Redundant States

**Time Cost of Computing
the List of $E C_V$ Matching**

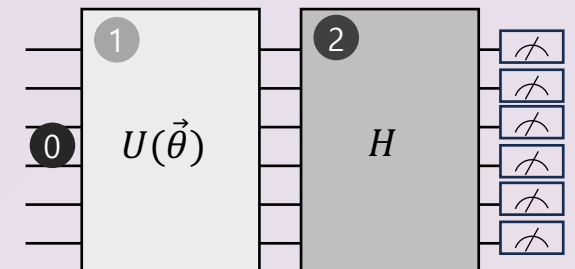

2. Trials

1

**Necessary
Cond.**

of connected edges per node = 2 $H := C^\dagger C$

Edges (# of 1s) = # Nodes(Vertices) \rightarrow **Dimension** \downarrow $H_r := THT^\dagger$

of 1 = $|V|$: **Number Preserving Ansatz**

$$|101111\rangle \rightarrow_U a_0|011111\rangle + a_1|101111\rangle + a_2|110111\rangle + a_3|111011\rangle + a_4|111101\rangle + a_5|111110\rangle$$
$$\sum_i |a_i|^2 = 1$$

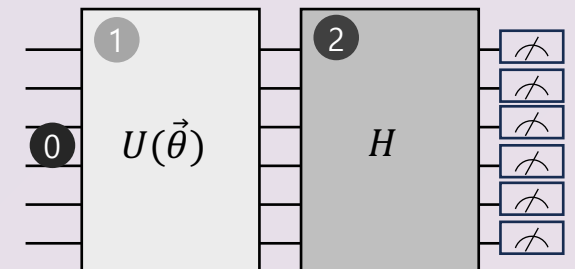

Reference : Gian-Luca R Anselmetti *et al* 2021 *New J. Phys.* **23** 113010, 2021

2. Trials

1

**Necessary
Cond.**

of connected edges per node = 2 $H := C^\dagger C$

Edges (# of 1s) = # Nodes(Vertices) \rightarrow **Dimension** \downarrow $H_r := THT^\dagger$

of 1 = $|V|$: **Number Preserving Ansatz**

Using isingXY Gate

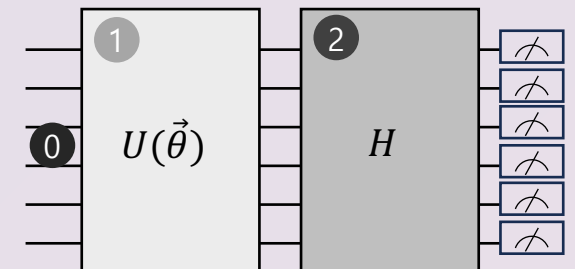
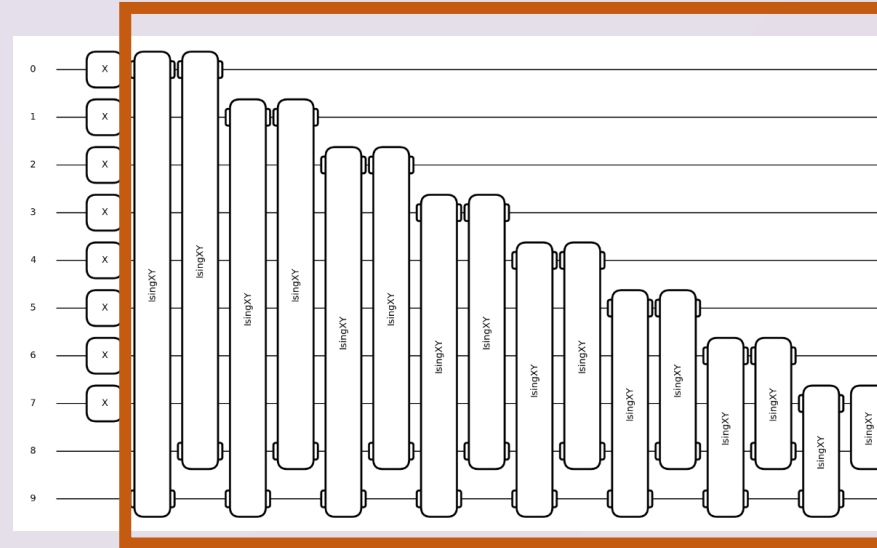
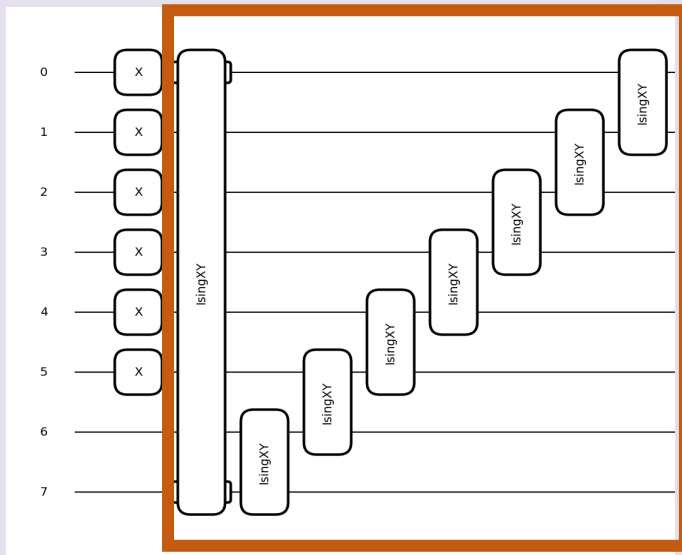

Reference : Gian-Luca R Anselmetti et al 2021 New J. Phys. 23 113010, 2021

3. Method

Necessary Cond.

of connected edges per node = 2 $H := C^\dagger C$

Edges (# of 1s) = # Nodes(Vertices) → **Dimension** ↓ $H_r := THT^\dagger$

of 1 = $|V|$: **Number Preserving Ansatz**

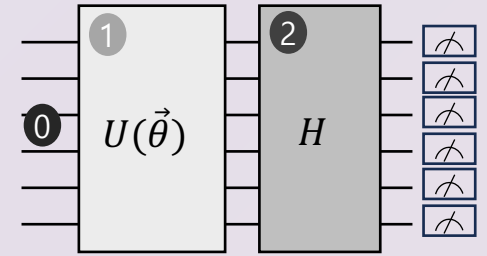

방법 이름	Layer(1)	Hamiltonian(2)
노가다		$H := C^\dagger C$
차원 축소		$H_r := THT^\dagger$
IsingXY_1		$H := C^\dagger C$
IsingXY_2		

3. Method

Necessary Cond.

of connected edges per node = 2 $H := C^\dagger C$

Edges (# of 1s) = # Nodes(Vertices) \rightarrow **Dimension** \downarrow $H_r := THT^\dagger$

of 1 = $|V|$: **Number Preserving Ansatz**

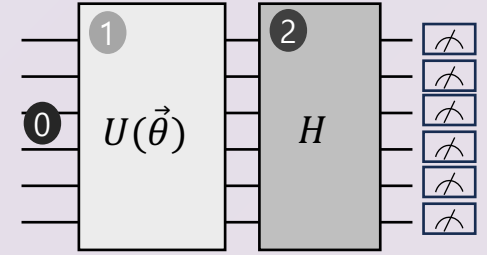

방법 이름	Layer(1)	Hamiltonian(2)
노가다		$H := C^\dagger C$
차원 축소		HT^\dagger
IsingXY_1		C^\dagger
IsingXY_2		

3. Method

Necessary Cond.

of connected edges per node = 2 $H := C^\dagger C$

Edges (# of 1s) = # Nodes(Vertices) \rightarrow **Dimension** \downarrow $H_r := THT^\dagger$

of 1 = $|V|$: **Number Preserving Ansatz**

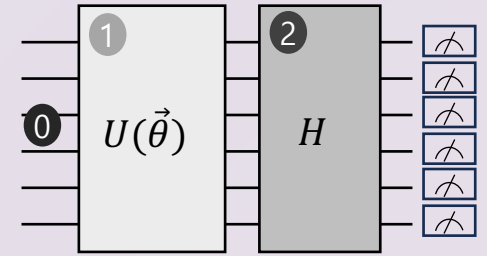

방법 이름	Layer(1)	Hamiltonian(2)
노가다		$H := C^\dagger C$
차원 축소		$H_r := THT^\dagger$
IsingXY_1		$H := C^\dagger C$
IsingXY_2		

NOGADA RESULT
 136.58942 sec
 expectation value of energy : 2.0000453071069777
 1101101101 is ground state with probability 0.9990891663921889

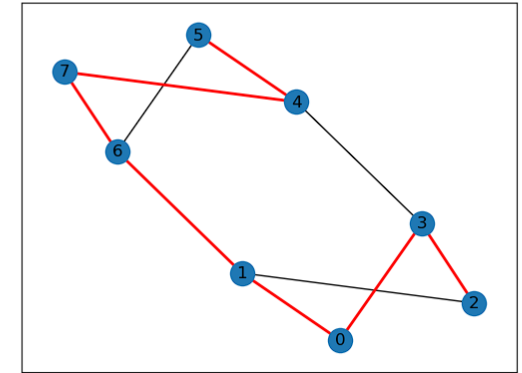

3. Method

Necessary Cond.

of connected edges per node = 2 $H := C^\dagger C$

Edges (# of 1s) = # Nodes(Vertices) → **Dimension** ↓ $H_r := THT^\dagger$

of 1 = |V| : **Number Preserving Ansatz**

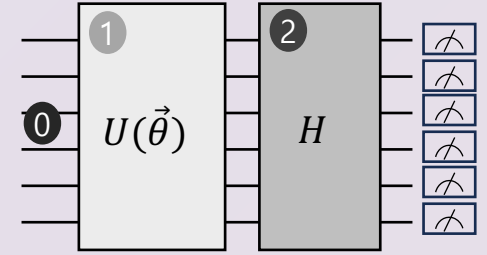

방법 이름	Layer(1)	Hamiltonian(2)
노가다		$H := C^\dagger C$
차원 축소		$H_r := THT^\dagger$
IsingXY_1		$H := C^\dagger C$
IsingXY_2		

NOGADA RESULT
 37.21615 sec
 expectation value of energy : 2.487727522667273e-11
 1101111 is ground state with probability 1.0000005926027098

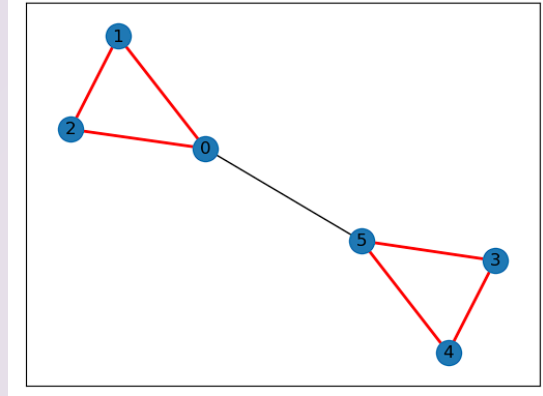

4. Result

Hamiltonian
Cycle 있음

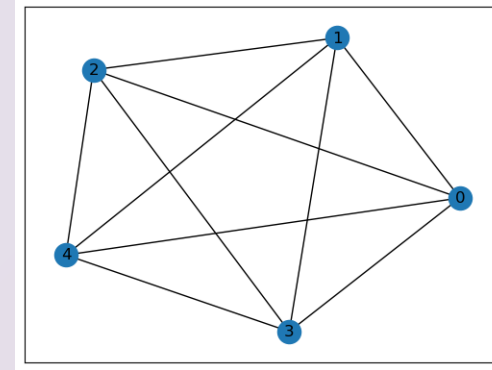
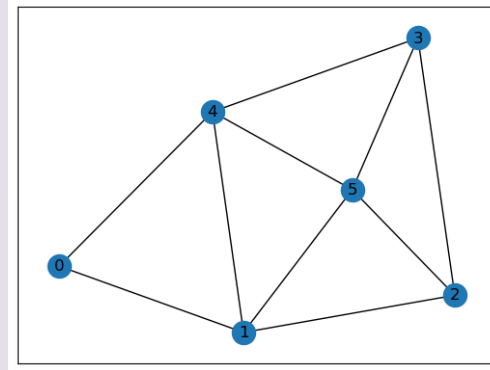
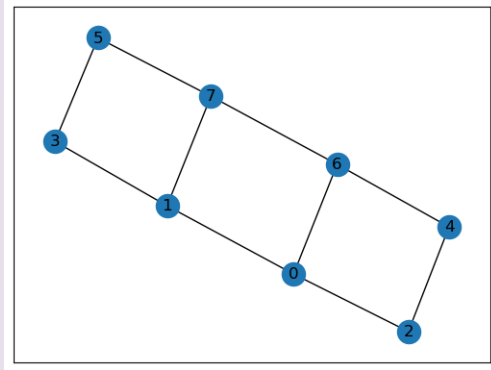

Hamiltonian
Cycle 없음

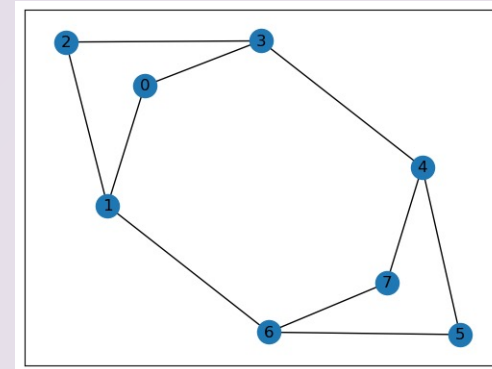
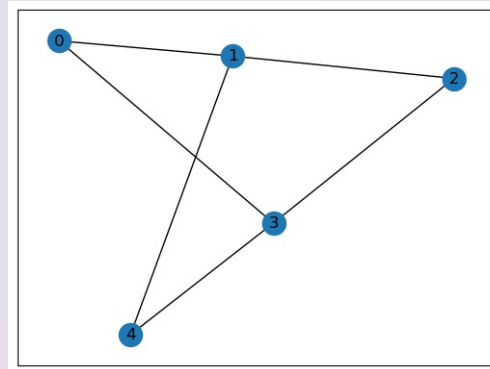
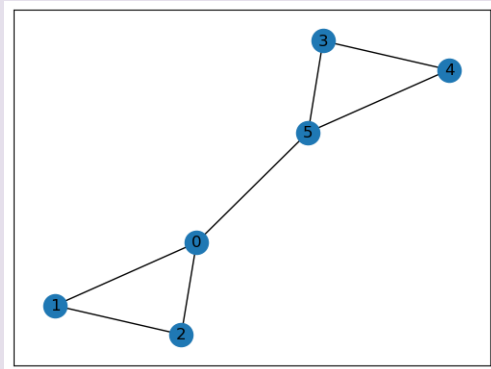

4. Result

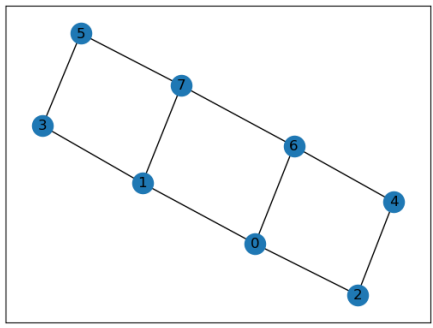

Iterations=800
Lr=0.05,
momentum=0.05

	노가다	차원 축소	IsingXY_1	IsingXY_2
EXP. Val.	2.000	1.903e-3	6.882e-3	1.073e-7
Time	115.238	28.976	47.424	46.569
# Layer	4	3	5	3

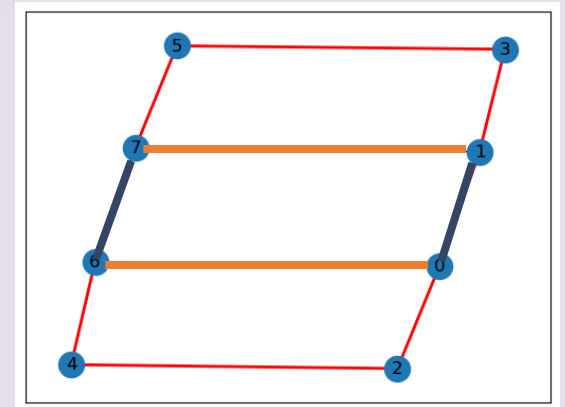
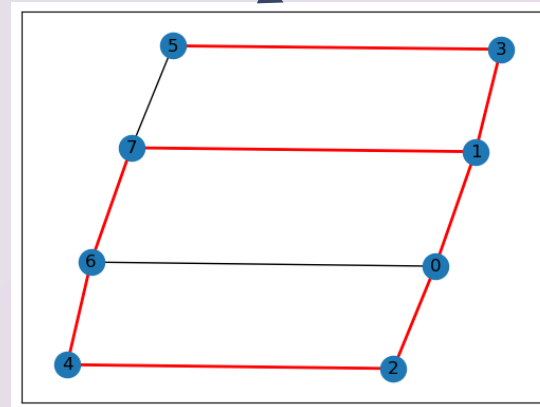
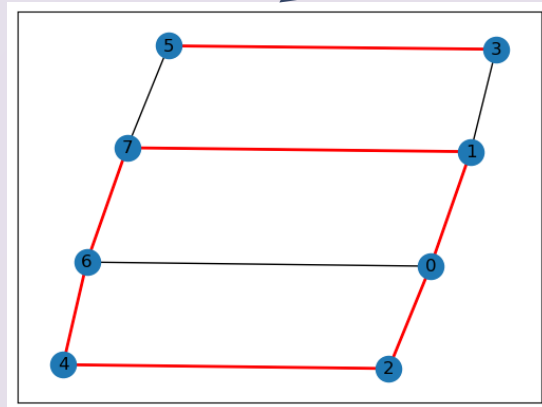

4. Result

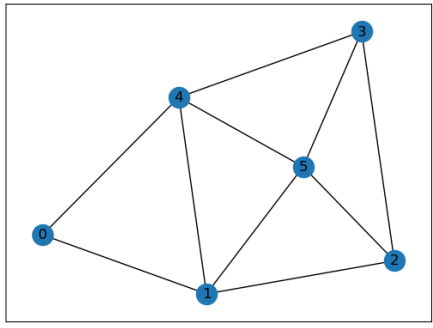

Iterations=500
Lr=0.05,
momentum=0.05

	노가다	차원 축소	IsingXY_1	IsingXY_2
EXP. Val.	2.000	7.202e-5	1.166e-3	4.478e-3
Time	43.668	158.419	23.240	29.403

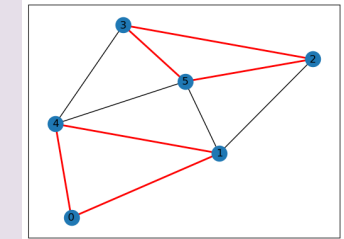
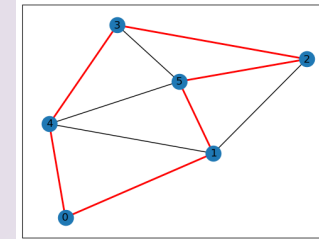
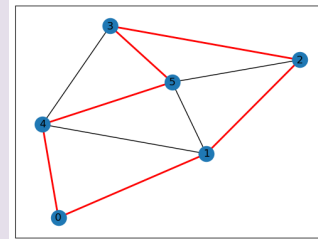
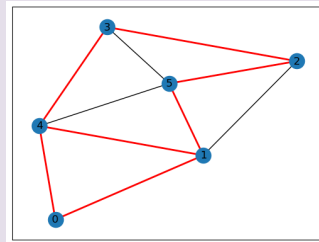
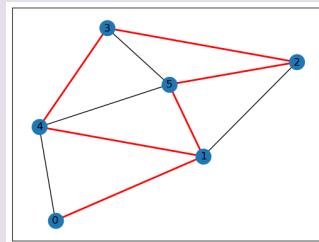

4. Result

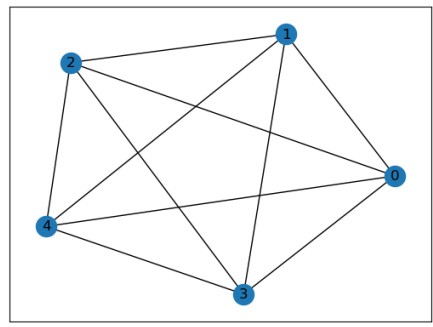

Iterations=800
Lr=0.05,
momentum=0.05

	노가다	차원 축소	IsingXY_1	IsingXY_2
EXP. Val.	7.678e-5	2.148e-4	9.174e-4	5.599e-3
Time	69.686	255.324	36.514	47.018

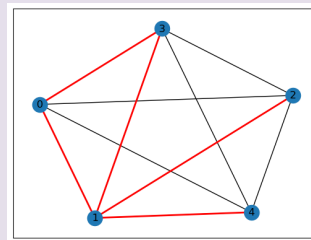

prob=0.066

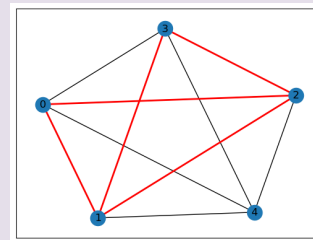

prob=0.499

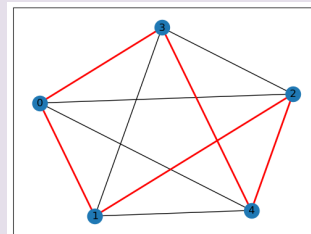

prob=0.934

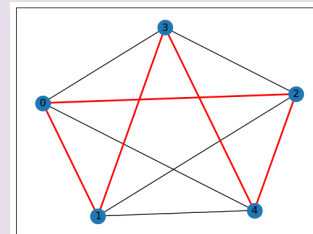

prob=0.499

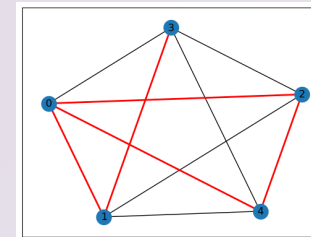

prob=0.999

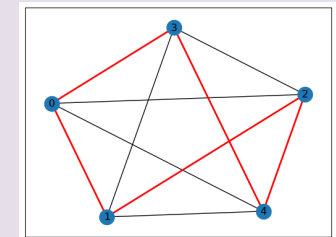

prob=0.997

4. Result

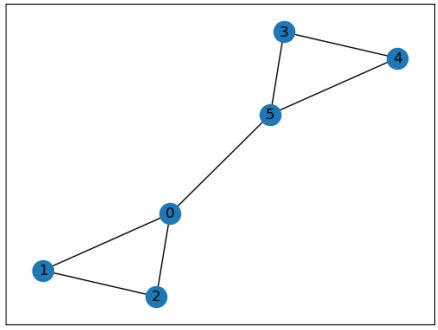

Iterations=800
Lr=0.05,
momentum=0.05

	노가다	차원 축소	IsingXY_1	IsingXY_2
EXP. Val.	2.487e-11	3.286e-4	9.569e-4	2.489e-5
Time	27.216	9.432	19.607	13.611

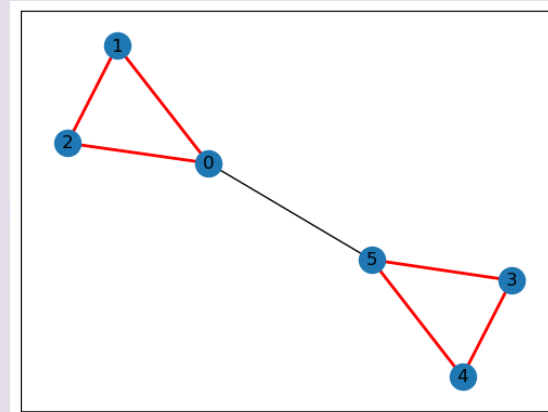

4. Result

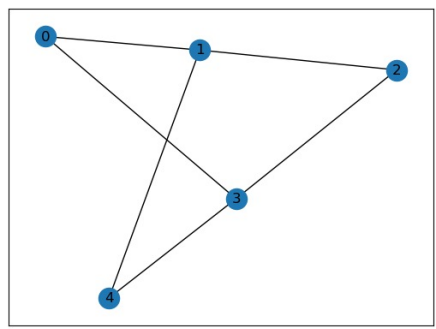

Iterations=1500
Lr=0.05,
momentum=0.05

	노가다	차원 축소	IsingXY_1	IsingXY_2
EXP. Val.	2.000	2.000	1.999	1.999
Time	58.264	17.697	31.016	21.181

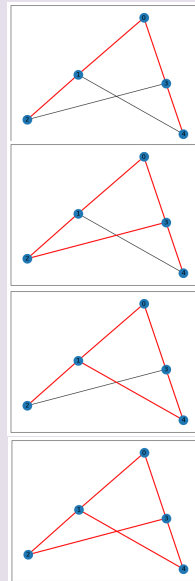

prob = ~0.25

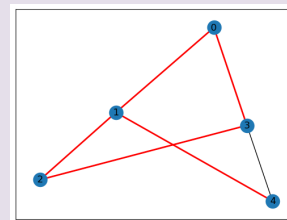

prob=0.275

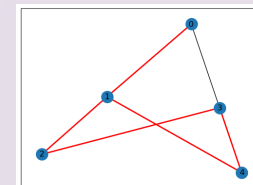

prob=0.436

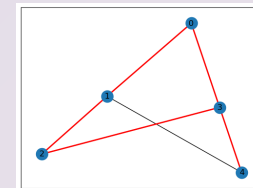

prob=0.215

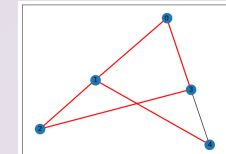

prob=0.038

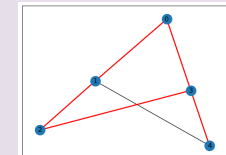

prob=0.759

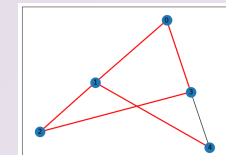

prob=0.151

4. Result

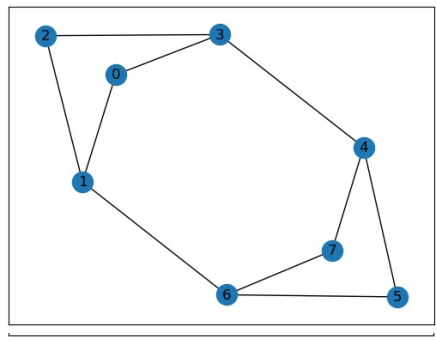

Iterations=1500
Lr=0.05,
momentum=0.05

	노가다	차원 축소	IsingXY_1	IsingXY_2
EXP. Val.	2.000	2.000	5.281e-11	5.242e-6
Time	136.589	55.070	73.273	70.797

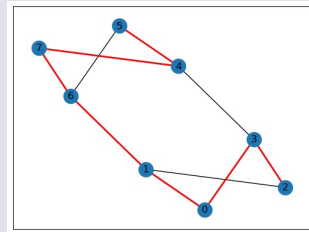

prob=0.999

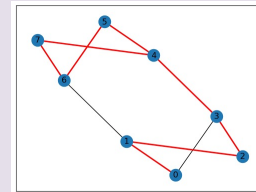

prob=0.365

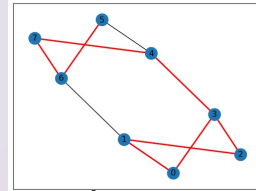

prob=0.530

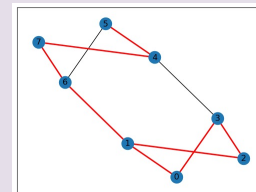

prob=0.106

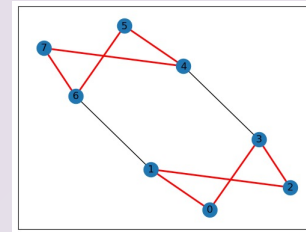

prob=1.000

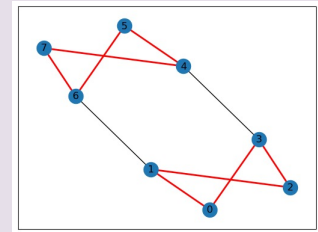

prob=0.999

QnA

감사합니다

Reference

1. Gian-Luca R Anselmetti *et al* 2021 *New J. Phys.* **23** 113010, 2021